

Flextool TuffTruk B450E Electric Mini Dumper

The Flextool TuffTruk B450E is designed for use in the construction, hire and manufacturing industries. Ideal for interior demolition, general construction, landscaping, and utility work, the Flextool TuffTruk is engineered to move all types of materials across various rough terrains. Operator safety and job efficiency are optimised with the many superior features, resulting in improved site safety and reduced labour cost. Its compact size and articulated steering function provide maximum versatility and ultimate manoeuvrability. This battery powered model offers eight hours runtime, has zero operating emissions, and is quiet to run, making it ideal for noise sensitive environments and indoor use.



Features

- Large capacity poly tray of up to 450kg for easy cleaning and reduced noise
- Two stage self-tipping skip means no manual lifting
- Ultimate tip angle means totally empty skip
- Articulated steering function allows precise and easy steering in hard to access spaces
- Battery powered with 8 hours runtime and zero operating emissions
- Automated motor brake system with safe parking mode
- Constant hydrostatic 4WD design
- Wide profile mud gripper tyres for ultimate traction and drive
- Offset rim wheels can be flipped to reduce operating width to match the narrow bucket (730 mm) which can fit through a standard doorway
- Low maintenance, durable fully sealed hydrostatic drive system
 - No separate gear boxes or drive belts



**BRENDALE
VIRGINIA
KELVIN GROVE
MOOROOKA**

Specifications

Max Payload (kg/m3)	450 / 0.3
Operating Width (mm)	850
Unladen Operating Weight (kg)	255
Working Gradient (deg)	25
Drive & Controls	24 V Motor Gearbox
Brake System	Hydrostatic
Tyres (Standard)	Gripper Pneumatic
Travel Speed Fwd / Rev (km/h)	5.6 / 2.4
Noise level (dB)	< 76
Hand Arm Vibration (m/s ²)	2.5
Engine / Motor	DC Brushless
Engine Motor Power	1000 W / 24 V
Fuel Type	2 x 12V AGM Batteries

TURNING CIRCLE

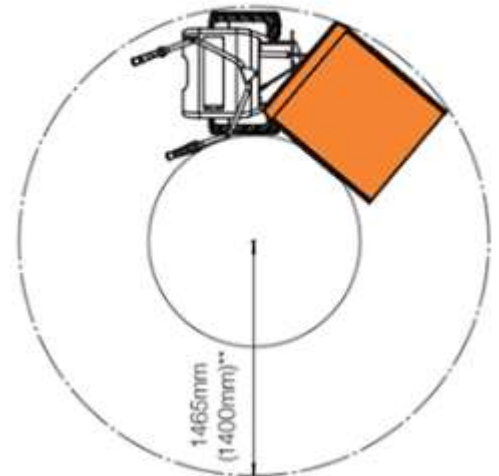

DIMENSIONS

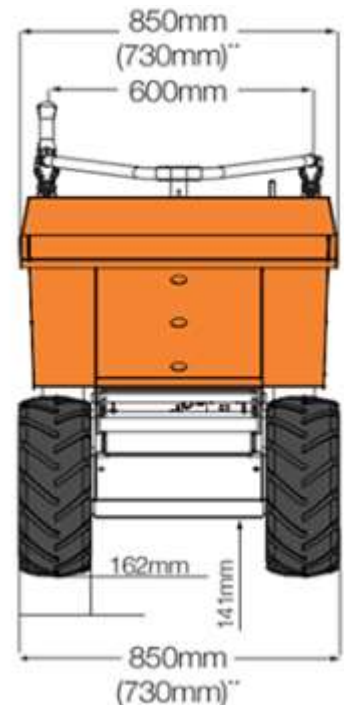
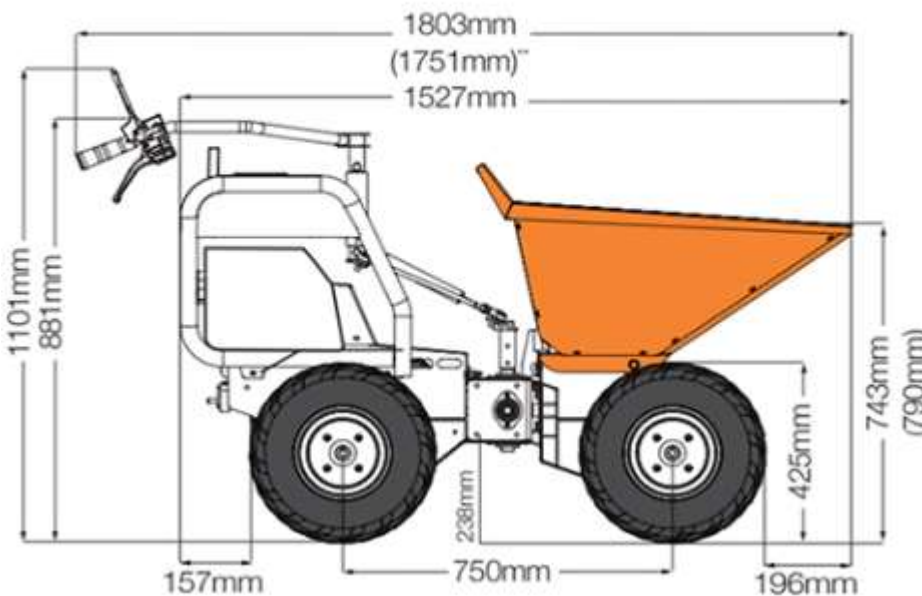

CENTRAL KELVIN GROVE

3352 5122

12 Herston Rd
kelvingrove@cityhire.com.au

SOUTHSIDE MOOROOKA

3848 4444

1049 Ipswich Rd, Cnr Michlin St
moorooka@cityhire.com.au

NORTHSIDE BRENDALE

3881 2266

176 South Pine Rd
brendale@cityhire.com.au

NORTHEAST VIRGINIA

3352 5775

20 Shannon Pl
virginia@cityhire.com.au

DIY • Trade • Construct • Renovate
Toilets • Power Poles • Site & Pool Fence
Bobcats • Excavators • Miniloaders
Aluminium Scaffold • Trestles • Planks
Cherry Pickers • Scissor Lifts • Booms
Props • Duct Lifts • General Tools